

Bathroom Fan Control

Tom Schmidt

<http://www.tschmidt.com>

10/13/2009

In the beginning

When we built our home knew humidity control would be an issue because it is so tightly constructed. Home has two bathrooms with an exhaust fan in each one. Upstairs bathroom has a skylight that is not convenient to open for ventilation. First floor bathroom has operable window.

During design phase did not put a lot of effort into thinking about exhaust fan control. Each bathroom has two switches one for light and one for fan. Over the years have experimented with different types of control. This paper discusses the pros and cons of each method.

Note: For simplicity ground wiring is not shown. Per National Electrical Code (NEC) all devices/fixtures need to be grounded.

Version 1: Dual Single Pole Switches

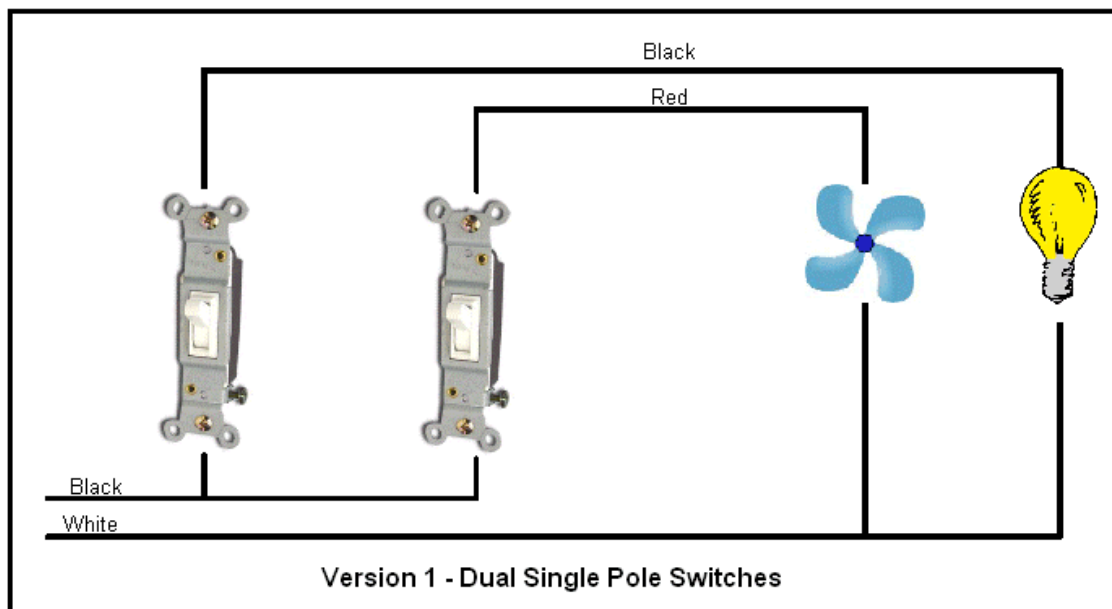

First implementation simply had two single pole (SPST) switches by each bathroom door, one for lighting other for fan. Worked for years but had to remember to turn fan on/off. Turning fan off immediately after taking a shower does not run it long enough to bring humidity down to acceptable levels.

Version 2: 3-Way Fan Switch

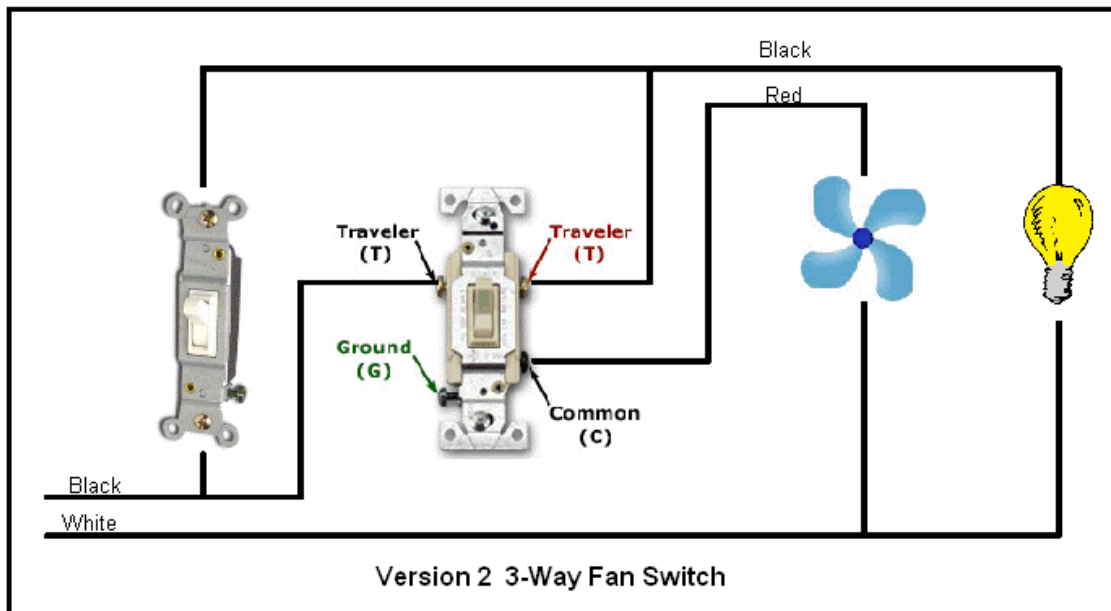

In thinking about the problem realized 3-way switch, used when two switches control a single light fixture, could automatically control fan. A 3-way switch is single pole double throw (SPDT) switch. When toggle is up common is connected to one terminal, when toggle is down common connected to other terminal.

I replaced existing fan switch with 3-way. New switch is wired so in up position fan runs constantly. When down runs when light is on.

This solved problem of automatically turning fan on when bathroom was in use but unless manually overridden turning light off also turns off fan. Ideally fan should run longer to bring humidity levels down after a shower.

Version 3: Occupancy Sensor

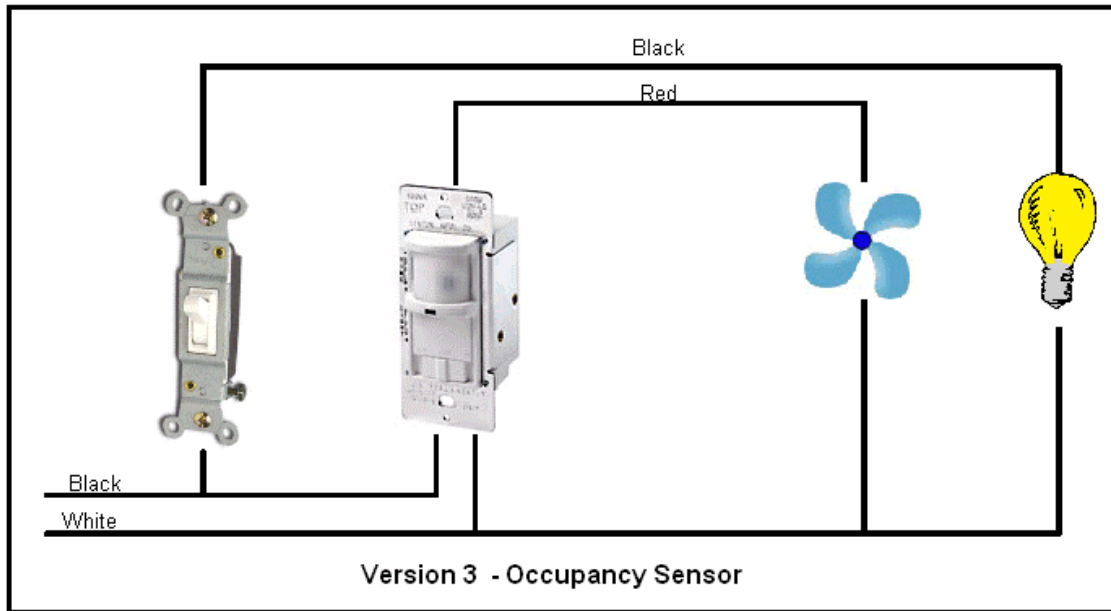

Next we tried an occupancy sensor. These are commonly used to control lights in commercial buildings. Fan runs when bathroom is occupied. When sensor detects room is vacant keeps fan on for a delay period before turning it off.

In theory should have been the way to go but we ran into several complications. Sensor would trigger randomly. This appears to be caused by light/shadows from North facing skylight. We have a small fan to circulate air in the room. When it is on air movement confuses sensor turning fan on, or preventing it from turning off. Fan would run for hours at a time. Lastly we have animals, if they enter the room sensor is triggered turning on fan.

Version 4: Fan Timer

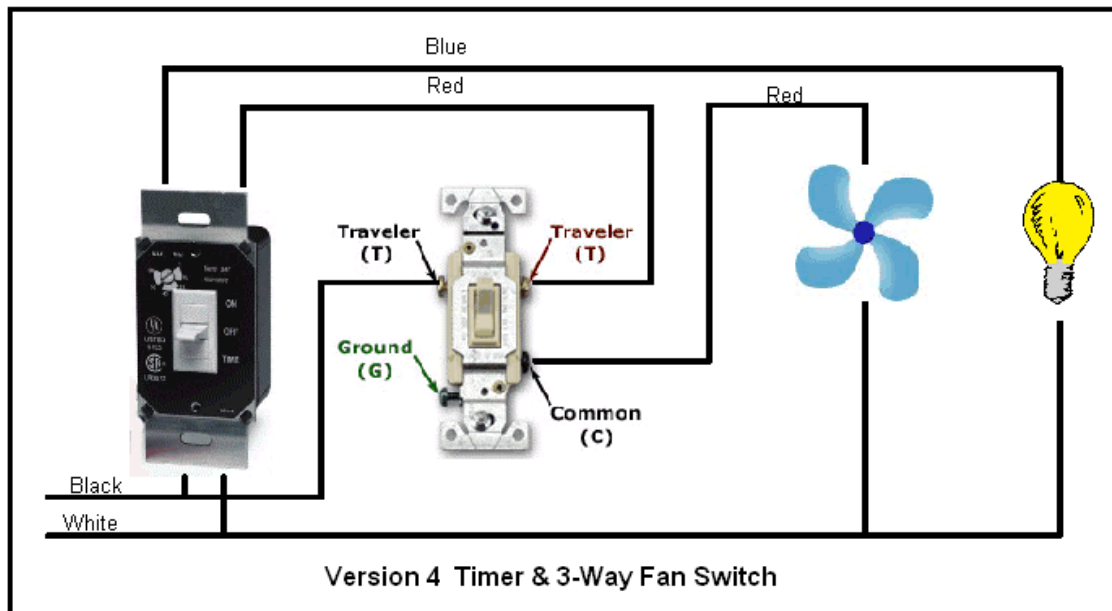

Ran across switch/timer combo designed specifically for bathroom fan control. There are several versions on the market. I chose an [Air King AKDT60](#). Device costs about \$25 and fits in a single gang space.

Wired timer in conjunction with 3-way switch:

- 1) Fan is on when light is on.
- 2) Fan stays on for a programmed delay (up to 60 minutes) when light turned off.
- 3) Module has a center off position that turns fan off immediately when light is off.
- 4) 3-way switch overrides timer. In down position fan goes on/off with light. In up position runs constantly independent of light.

I have mixed feelings about timer center off position. It is nice being able to manually turn fan off when not needed. However there is a tendency not to push switch all the way down when turning off light. This may be more of a matter of getting use to how the switch works. So far this latest arrangement is working well.

Another option is to directly measure bathroom humidity. There are a number of inexpensive solid-state sensors on the market but I'm not aware of a turnkey module purpose designed for the task.